

Amcargobikes

Cargo bike enthusiast since 1992



Electric Cargo Bike Ultimate Harmony

Assembly Instructions

Read the manual carefully before starting the assembly. The bike is assembled in several different stages. It is important to read the operating instructions carefully before assembly begins, so the bike is mounted in the correct order.

It is recommended to be two people to mount the cargo bike.

Note that all nuts and screws on the bike must be tightened after about a month of use. Be sure to check all parts of the bike and tighten all screws and bolts.

Amcargobikes

Cargo bike enthusiast since 1992

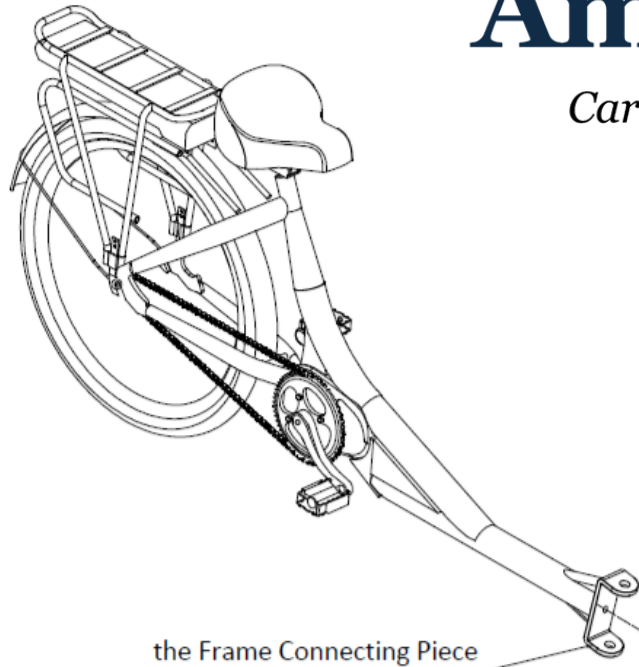

the Frame Connecting Piece

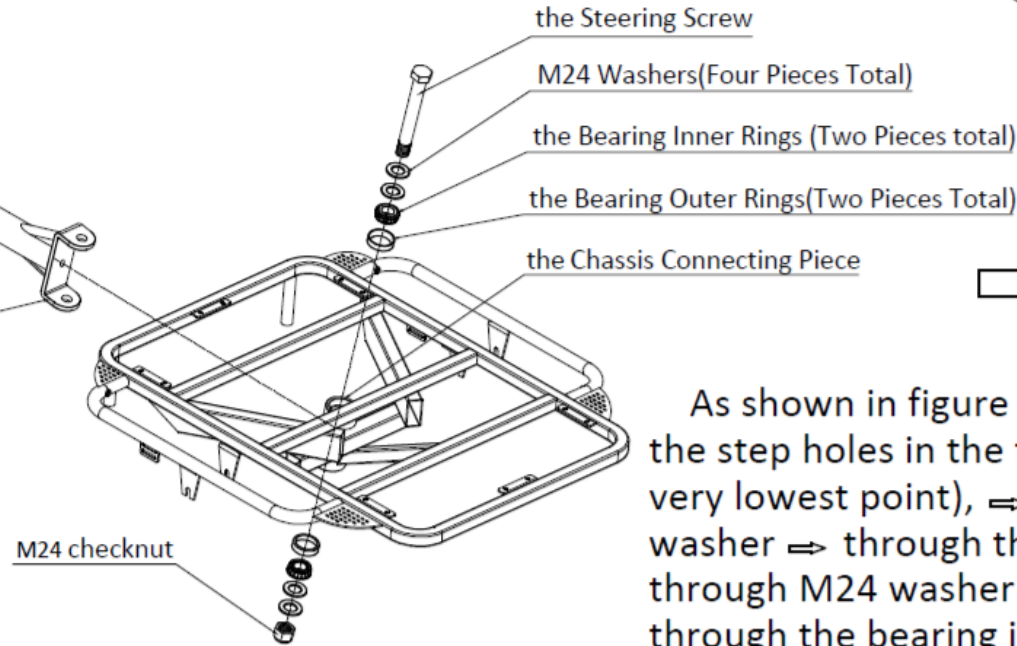

the Steering Screw

M24 Washers(Four Pieces Total)

the Bearing Inner Rings (Two Pieces total)

the Bearing Outer Rings(Two Pieces Total)

the Chassis Connecting Piece

M24 checknut

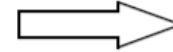
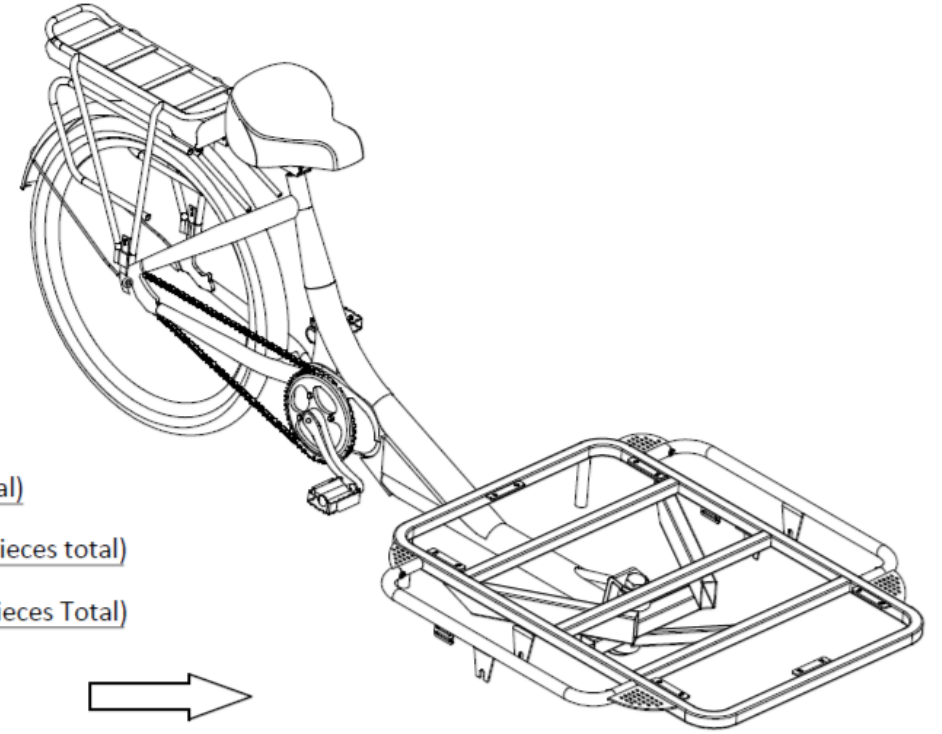

As shown in figure 1, first of all press the bearing outer rings into the step holes in the two sides of the chassis connecting piece (to the very lowest point), ⇒ then put the steering screw through M24 washer ⇒ through the upper hole of the frame connecting piece ⇒ through M24 washer ⇒ through the chassis connecting piece ⇒ through the bearing inner ring ⇒ through M24 washer ⇒ through the lower hole of the frame connecting piece ⇒ through M24 washer ⇒ last of all tighten M24 checknut;

1

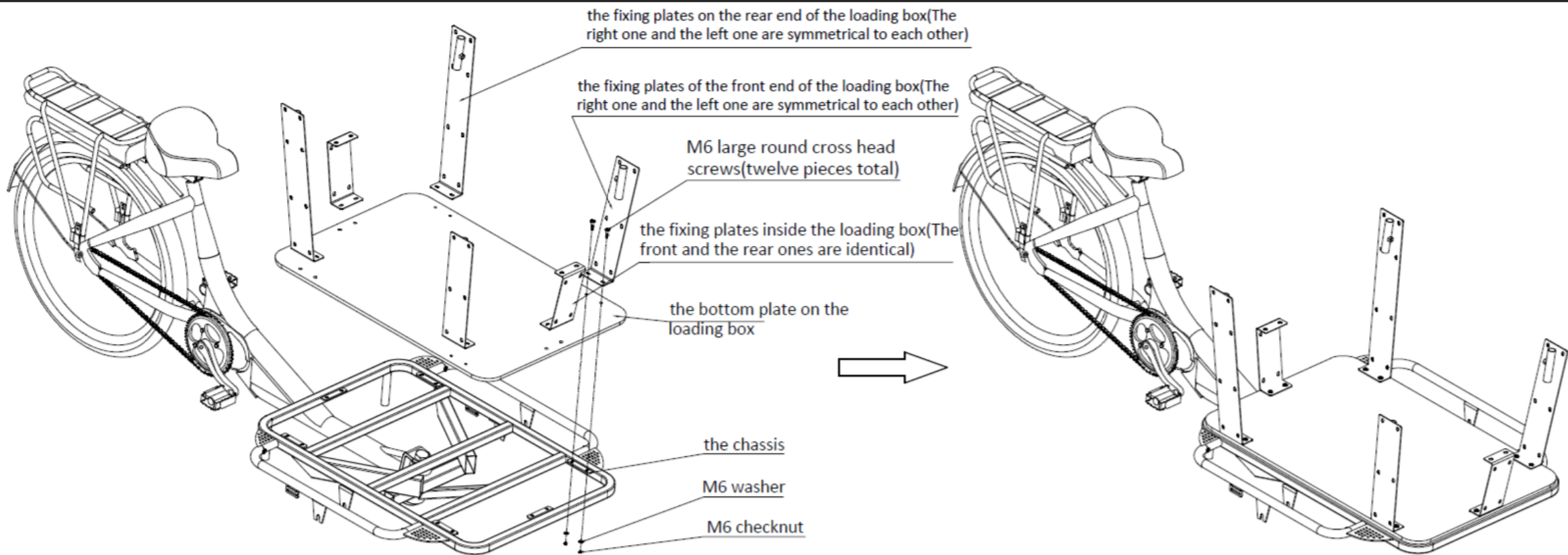

Amcargobikes

Cargo bike enthusiast since 1992

2

As shown in Figure 2, with M6 large round cross head screw, connect the front, the middle, and the rear fixing plates to the bottom plate on the loading box and the loading box chassis, put the M6 washer, and screw on the M6 checknut (Note that please do not twist it too tight so that the fixing plates are removable and the loading box is adjustable.)

Amcargobikes

Cargo bike enthusiast since 1992

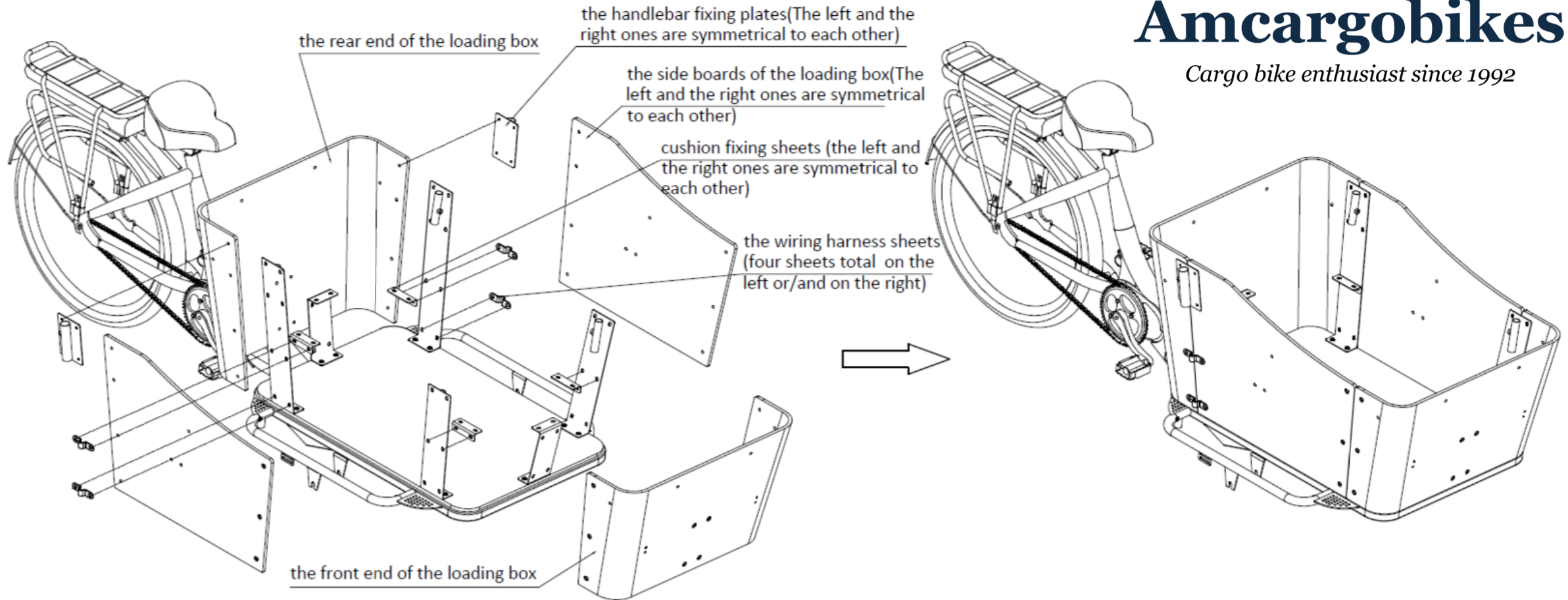

As shown in Figure 3, with an interlocking screw, connect the front and the rear boards of the loading box to the fixing plates of the loading box (As for the sizes of the screws, please refer to the loading box screw specification diagram), when connecting with the screws, please put the corresponding spare parts on as shown in Figure 3, please do not tighten the screw too much before all the screws are put and the bottom of the box is adjusted to its best position, then tighten the 12 M6 large round cross head screws on the bottom plate of the loading box, and last of all tighten all the interlocking screws on the loading box;

3

Amcargobikes

Cargo bike enthusiast since 1992

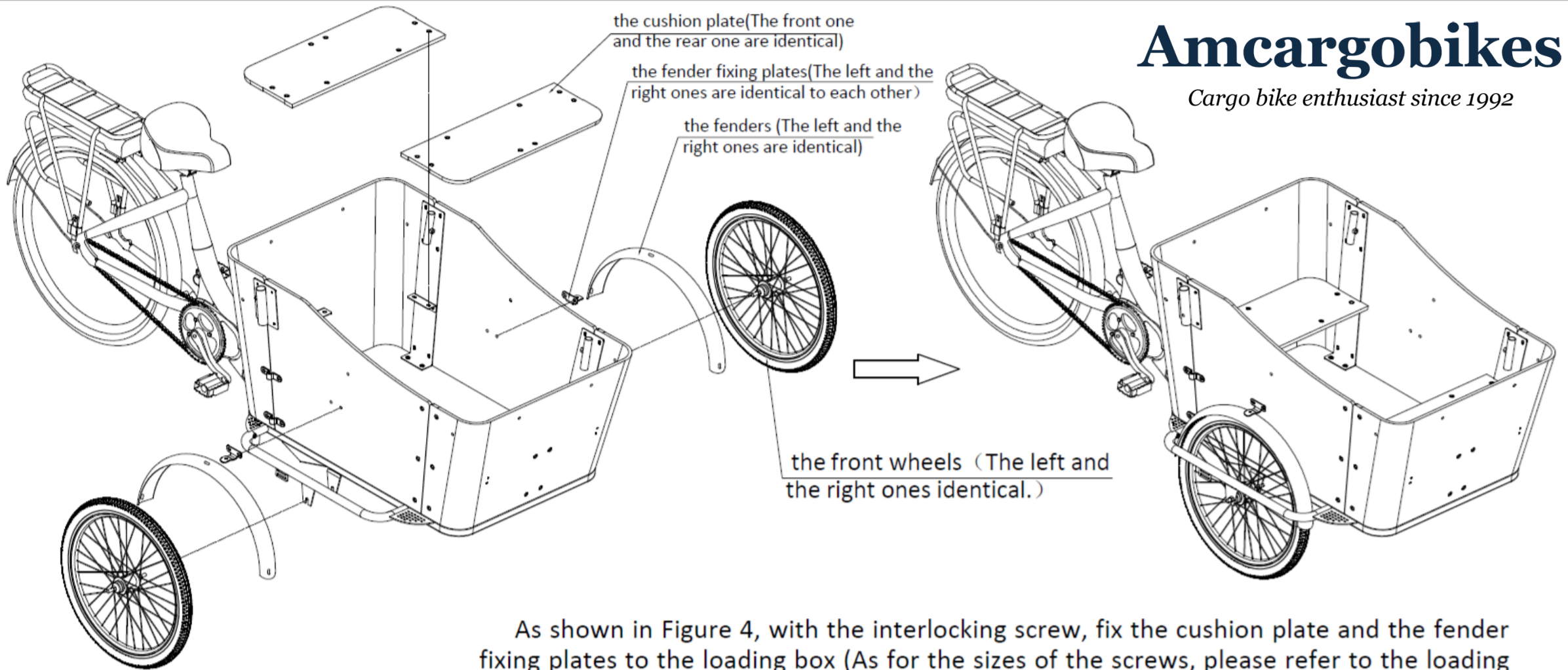

As shown in Figure 4, with the interlocking screw, fix the cushion plate and the fender fixing plates to the loading box (As for the sizes of the screws, please refer to the loading box screw specification diagram), then install the left and the right fenders, and last of all install the left and the right wheels and lock the fixing screws of the clasp brake;

4

Amcargobikes

Cargo bike enthusiast since 1992

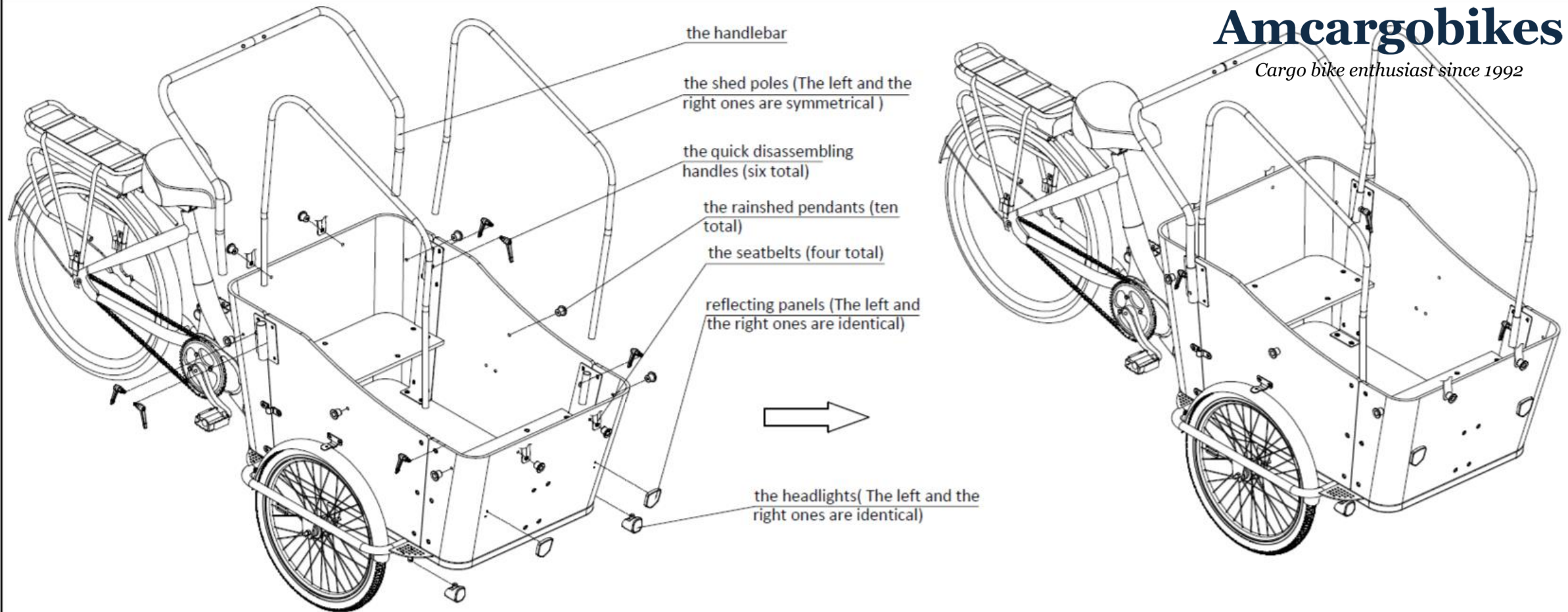

As shown in Figure 5, first connect the quick disassembling handles, the reflecting panels, the headlights, and the rainshed pendants to their corresponding positions on the loading box, when the rainshed pendants are fixed, please note that the seatbelts should be added both in the front and in the rear (The other end of the seatbelt should be connected to the corresponding holes in the cushion plate, as for the sizes of the screws, please refer to the loading box screw specification diagram), then install the handlebar and the shed poles (The inserted depth should be flush with the bottom of the casing), tighten the quick disassembling handle screws, and last of all organize the brake wires, the shift cables, and the power wiring harness, and you will complete your installation.

5

Tricycle Screws Specification Diagram

(Note: the loading box screws are identical both on the right and on the left, and in front and in rear)

Amcargobikes

Cargo bike enthusiast since 1992

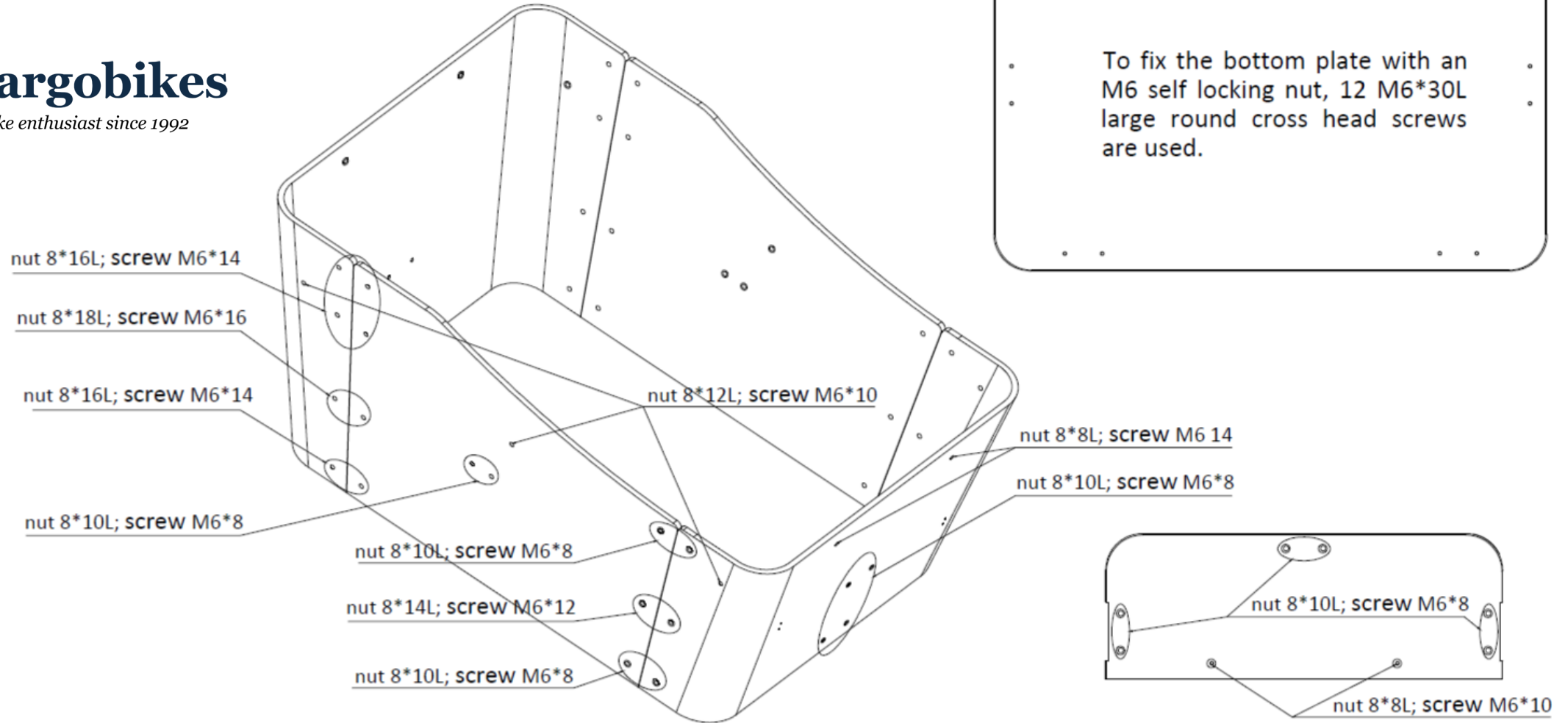

Amcargobikes

Cargo bike enthusiast since 1992

See link for assembly video of hydraulic brakes:

Tektro brakes

<https://amladcyklar.se/wp-content/uploads/2020/06/Film-montering-af-hydraulik-bremser-Assembly-of-hydrolic-brakes.mov>

Bengal Brakes

<https://amcargobikes.co.uk/wp-content/uploads/2022/01/Bengal-montering-video-1.mp4>

<https://amcargobikes.co.uk/wp-content/uploads/2022/01/Bengal-montering-video-2.mp4>