

# **amladcykler.dk**

## **ELECTRIC LONG JOHN**



## **ASSEMBLE INSTRUCTIONS**

Read and understand these instructions before you begin the assembly. The bike comes partly assembled, and it is important to read the manual carefully before starting assembly, so the bicycle will be assembled in the correct order. It is recommended to be two people to assemble the cargo bike. Be aware that the bike must be re-tightened after some weeks of use. Make sure to check all parts of the bike and re-tighten all screws and bolts.



1.Handle bar & brake lever 2.gear shift 3.brake lever 4.box 5.corner iron  
6.front light

7.Front wheel 8.front brake 9.fork 10. turning rod 11.park frame 12.frame

13.Chain cover & chain 14.chainwheel and crank 15.pedal 16.rear  
wheel 17.rear fender

18.rear reflector 19.seat post lock 20.seat post 21.saddle 22.rubber  
band 23. carrier

24. front fender

**amladcykler.dk**

Assemble the fender onto the fork as shown in figure below, and then put the wheel set between fork legs and lock it as figure 2. Adjust the V brake and brake cable length and lock it.

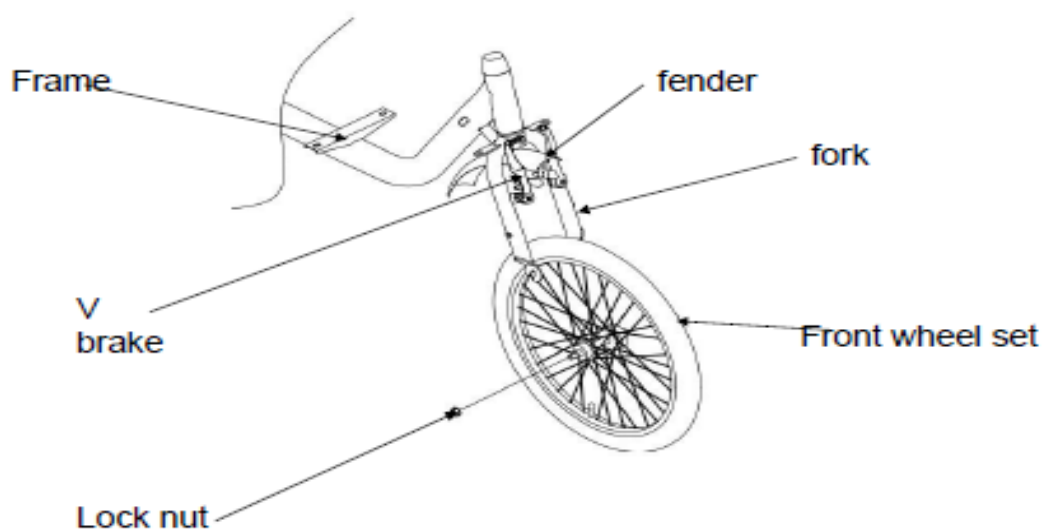

Assemble the parking stand on to the frame and lock it. And then pull on the spring as shown in figure 4.

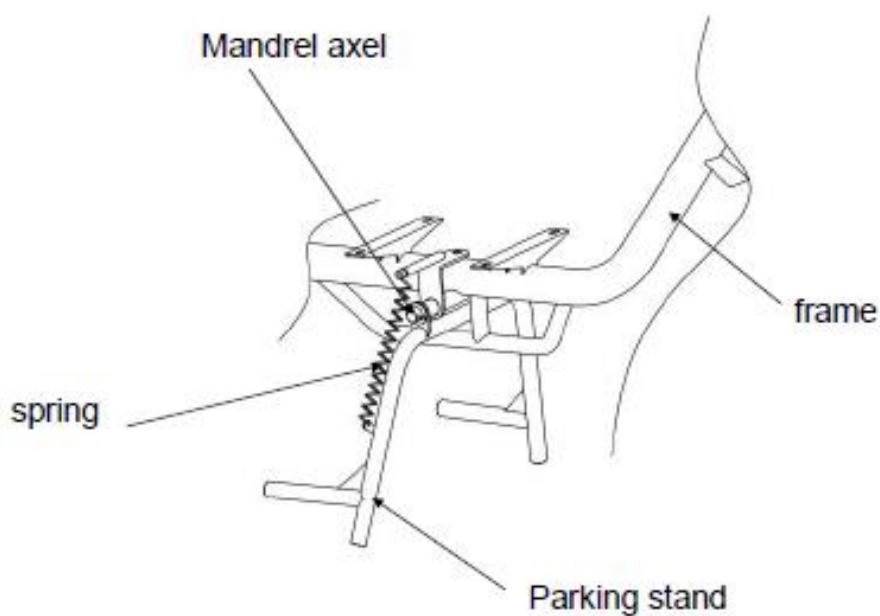

Assemble the handle bar as shown in figure below, adjust the lock it.

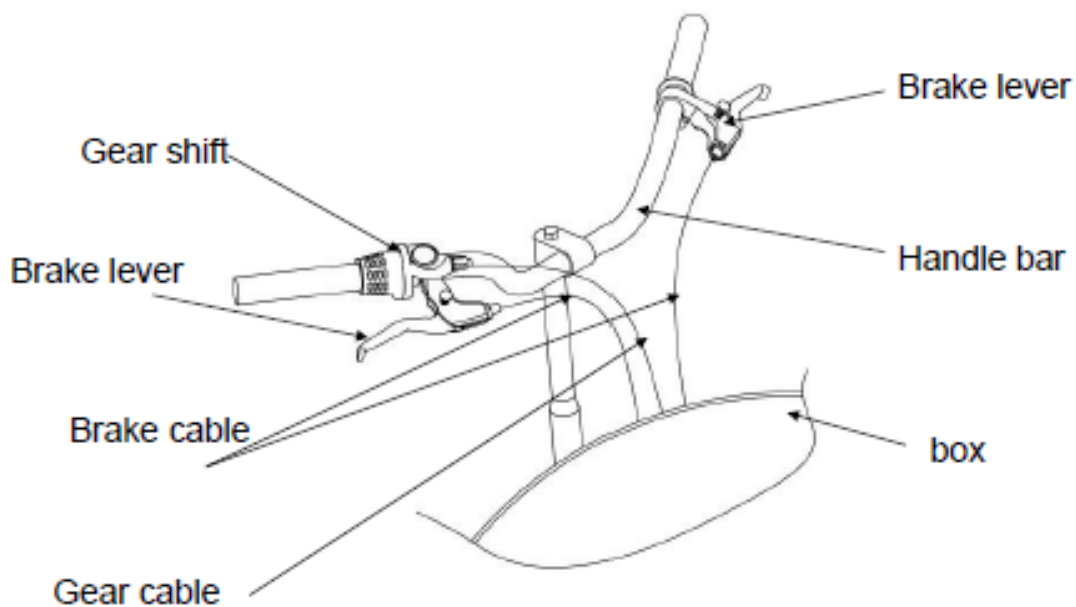

Assemble the box as shown in figure and fix it with bolt, fix the safety belt on the box.

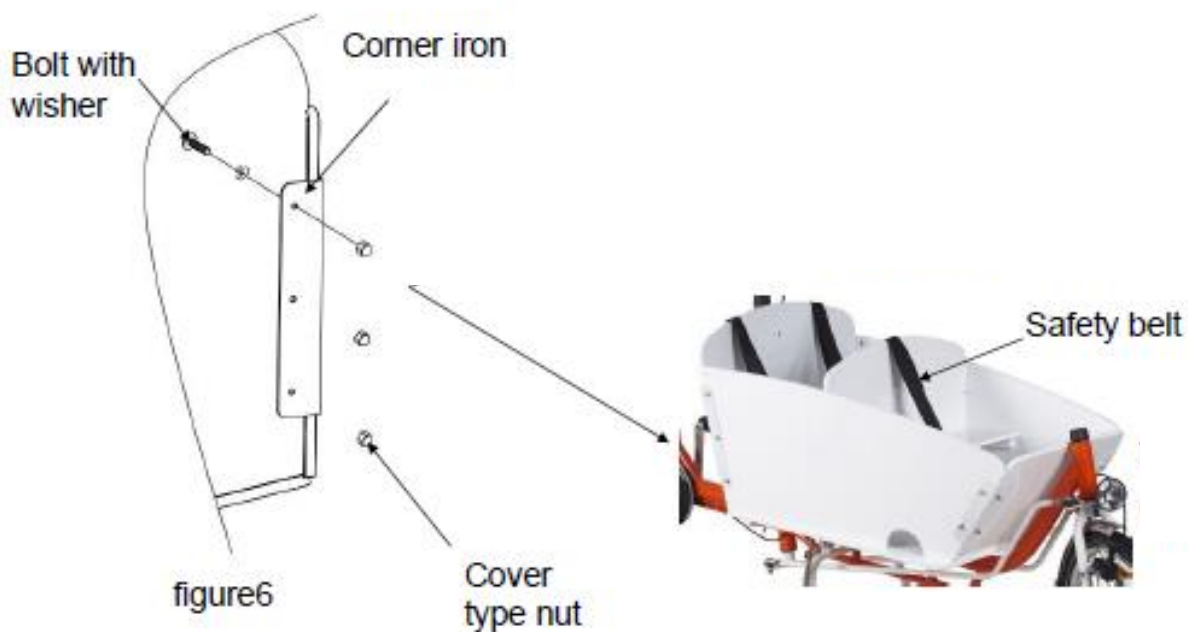

Insert seat post into the seat and lock it with nut as show in figure 9.

Put another end of post into the frame seat tube and lock the post lock. (Note: Safety line must be under the seat post lock )

